

NOTE:

This kit contains parts for servicing of the air-drive-motor only- (Bullard Part No. 17761).

17761 Kit Contains (See Reference Numbers on Drawings.)

- 4 - Composition vanes (4)
- 4 - Vane springs (5)
- 2 - Push pins (6)
- 1 - Drive end bearing (7)
- 1 - Dead end bearing (8)
- 1 - Shaft seal (11)
- 2 - Body gaskets (13)
- 1 - O-Ring (15)
- 1 - End cap gasket (17)

General

This air motor is precision built. The top clearance between ROTOR and BORE is .0015". End clearance between sides of rotor and end plates is .0035".

The 4 vanes take-up their own wear and will last 5,000 to 10,000 hours with proper use and maintenance:

- a. Use of Bullard's Micro-mist lubricator-adjusted to approximately 1-drop of recommended oil/minute.
- b. Properly adjusted INLET pressure - 80 to 110 psig range.
- c. Correct operating speed as determined by monitoring OUTLET pressure - 5 to 20 psig range.
- d. Leaving lubricated during shut-down periods.

Vane Replacement

An experienced mechanic may accomplish this easily:

1. Remove outboard end plate (2) (opposite the drive shaft end). Use a PULLER TOOL. Do not pry with screwdriver - this will dent the end plate and body causing leaks.
2. Clean chamber and rotor with approved solvents only.*
3. Lubricate chamber with a squirt of oil.
4. Install new vanes with the NOTCHED EDGE towards the bottom of the slot.

NOTE:

Pump Compressor Repair Kit for ADP Pumps is Bullard Part No. 15922.

1/2" NPT Female Pipe connection 1/2" NPT Female Pipe connection

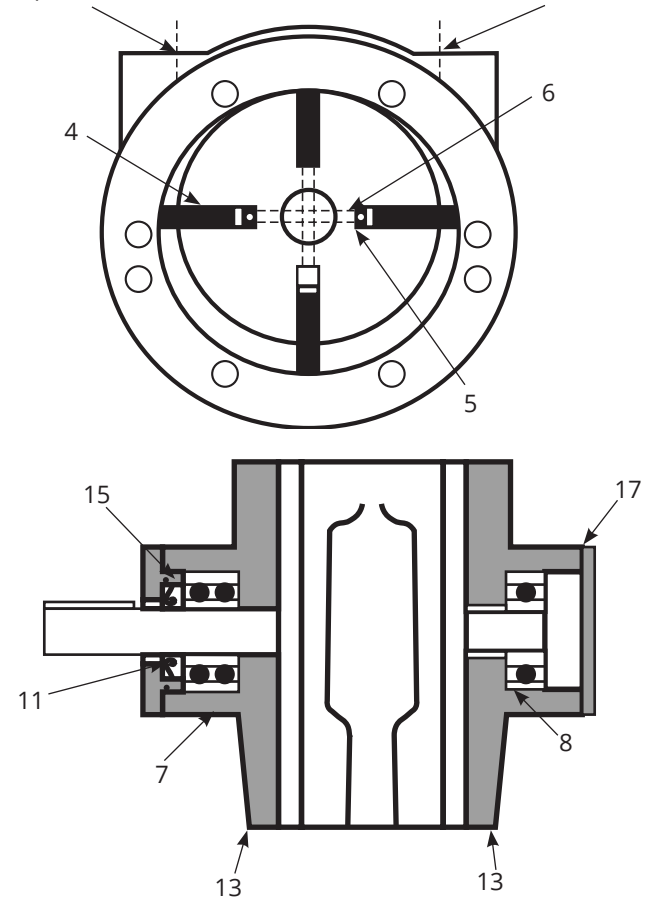

Complete Rebuild

1. Remove all piping from Air Motor.
2. Remove MOTOR GUARD.
3. Disconnect WOOD'S coupling (Allen screws).
4. Remove Air Motor from housing.
5. Replace all items provided in kit (bearings, seals, gaskets, etc.)

* Recommended solvents: Cleaning Solvent available as Bullard Part No. S17931,- GAST AH255HD SAFETY SOLVENT.

California Proposition 65 **WARNING**

Cancer and Reproductive Harm - www.P65Warnings.ca.gov.

Bullard Center
2421 Fortune Drive
Lexington, KY 40509 • USA
877-BULLARD (285-5273)
Tel: +1-859-234-6616
Fax: +1-859-246-0243

Americas:
E.D. Bullard Company
1898 Safety Way
Cynthiana, KY 41031-9303
877-BULLARD (285-5273)
Tel: 859-234-6616
Fax: 859-234-8987

Europe:
Bullard GmbH
Dieselstrasse 8a
53424 Remagen • Germany
Tel: +49-2642 999980
Fax: +49-2642 9999829

Bullard Asia-Pacific Pte. Ltd.
51 Changi Business Park
Central 2
#03-04 The Signature
Singapore 486066
Tel: +65 6745 0556



©2023 Bullard. All rights reserved.
Free-Air is a registered trademark of Bullard.